

Simulation Model of DVB-S2 System

Perica Baotic, Mario Draganic, Danko Bundalo, Ivan Kesegic, Dijana Tralic, Sonja Grgic

University of Zagreb, Faculty of Electrical Engineering and Computing

Department of Wireless Communications

Unska 3, HR-10000 Zagreb, Croatia

dijana.tralic@fer.hr

Abstract - This paper presents simulation model of the DVB-S2 (Digital Video Broadcasting - Satellite - Second Generation) system implemented in Simulink, Matlab. The model provides simulation of the DVB-S2 system parameters in AWGN (Additive White Gaussian Noise) channel. The aim of this model is to propose optimal DVB-S2 parameters in different propagation conditions. The simulation offers two modulation scheme options QPSK (Quadrature Phase Shift Keying) and 8PSK (8 Phase Shift Keying) with different code ratio values. During the simulation, BER (bit error rate) and PER (packet error rate) are calculated and the constellation diagram is observed. Simulation results, obtained by using two test images with different texture, showed that QPSK modulation is more robust compared to 8PSK modulation in the same propagation conditions. Simulink model results were compared with measurements of several Astra 1 satellite (19,2° E) transponders parameters. Lab-measured values achieved higher SNR values than simulation cases because of real wireless channel conditions. Optimal operation parameters for a DVB-S2 system according to channel conditions and the required bit rate are proposed.

Keywords - DVB-S2; FEC; Code Rate; Modulation; LDPC code; PER; BER

I. INTRODUCTION

DVB-S2 (Digital Video Broadcasting - Satellite - Second Generation) is built on the DVB-S (Digital Video Broadcasting - Satellite) system, with certain upgrades. It was developed by DVB Project in 2003 and is based on three concepts: the best transfer characteristic nearing the Shannon limit, complete flexibility, and an acceptable receiver complexity [1].

The DVB-S system uses QPSK (Quadrature Phase Shift Keying) modulation in conjunction with internal RS (Reed-Solomon) convolutional coding and FEC (forward error correction) [2]. The DVB-S2 system uses other modulation schemes in addition to QPSK [3]. For broadcasting over non-linear satellite transponders, QPSK and 8-PSK (8 Phase Shift Keying) are used, while 16-APSK (16 Amplitude and phase-shift keying) and 32-APSK (32 Amplitude and phase-shift keying) are utilized when a highly linear transponder and a better C/N (carrier-to-noise) ratio are available.

Error correction used in DVB-S2 utilizes BCH (Bose-Chaudhuri-Hocquenghem) with LDPC (Low Density Parity Check) internal coding, with its code ratio being 1/4, 1/3, 2/5, 1/2, 3/5, 2/3, 3/4, 4/5, 5/6, 8/9, or 9/10. In very unfavorable conditions - with E_b/N_0 (the energy per bit to noise power spectral density) ratio lower than 0 dB - 1/4, 1/3, or 2/5 code ratios with QPSK modulation scheme are mostly used [3].

Besides CCM (Constant Coding and Modulation) with fixed modulation schemes, DVB-S2 system also uses ACM (Adaptive Coding and Modulation) techniques for transfer characteristics optimization [4]. FEC and modulation scheme still remain unchanged within a single frame, but ACM usage allows to change between different frames. FEC utilizes bit interleaving for 8-PSK, 16-APSK, and 32-APSK modulation schemes in order to prevent error bursts and the subsequent data loss.

DVB-S2 system remains operational in conditions with C/N ratio starting at -2 dB (below noise level) with QPSK, and up to +16 dB with 32-APSK modulation scheme. C/N values lower than those may cause receiver synchronization issues, but DVB-S2 system provides additional pilot signals for carrier signal regeneration. This allows approximately 30% increase in bandwidth utilization efficiency compared to the DVB-S system [1].

This paper is organized as follows. Section II presents several basic features of DVB-S2 system with the exact system design used for this research. The comparison between DVB-S and DVB-S2 systems is also shown in Section II. The simulation and measurements results for QPSK and 8PSK modulations are given in Section III. In Section IV optimal DVB-S2 system parameters according to channel conditions are suggested. The conclusion is depicted in Section V.

II. TECHNICAL DESCRIPTION OF THE SIMULATION MODEL

The DVB-S2 simulation is realized in Simulink, Matlab, and shown in Fig. 1. Its main components are the following signal processing blocks:

- *BBFRAME Buffering block* - used to prepare BB (Base Band) frames to serve as input frames for the BCH encoder. All frames are arranged according to the BCH encoder input data size. Input data frames (188 byte or 1504 bit) are stacked up to the size determined by the number of information bits transferred within one BCH codeword. Where necessary, the input BCH frame is stuffed with zeroes to ensure the fixed size of all encoder input frames.
- *BCH encoder block* - performs forward error correction encoding. BB frames prepared in the BBFRAME Buffering block are processed by the BCH encoder. BCH encoder adds redundant bits that are used for correction of errors caused by transmission over error-prone wireless channel.

- *LDPC encoder block* - performs internal error correction encoding based on parity bit calculation and their insertion into the information bit sequence. In this simulation the output FEC frame (after BCH and LDPC encoding) will always retain a fixed size of 64800 bits. LDPC encoding is the last block of the error correction processing.
- *Block Interleaver* - performs interleaving of bits from received FEC frames in order to distribute energy and reduce burst errors. In the simulation, bit interleaving is performed by writing the frame data into columns and reading three consecutive columns as rows.
- *Modulator block* – performs signal modulation. The simulation offers two modulation scheme options: QPSK with any of the eleven code ratio values, and 8PSK with the 3/5, 2/3, 3/4, 5/6, 8/9, or 9/10 code ratio.

The Simulink-designed simulation covers the basic mechanisms of signal processing and transmission during signal broadcast in the DVB-S2 system. An image of 512x512 pixel is used as input data and processed with error correction encoding, modulation, wireless channel transmission, demodulation, and error correction decoding. Finally, output image is displayed at the receiving end. During the entire process the constellation diagram can be displayed and signal

quality measures, BER (bit error rate) and PER (packet error rate), are calculated.

There are, however, several differences compared to the DVB-S2 architecture standardized by [1]:

- AWGN channel block simulates the wireless channel which adds white Gaussian noise to the transmitted signal.
- It is assumed that the transmitter-receiver synchronization is ideal.
- Only normal 64800 bit FEC frames are used.
- SNR (signal/noise ratio) is user defined instead of being determined by the conditions in the wireless broadcast channel.
- 16APSK and 32APSK modulation schemes are not supported.
- Physical layer signaling, pilot signals, and physical layer encoding are not used.

Using the Matlab-designed model, a SNR value required to transmit data over the wireless channel without affecting the quality of the received image was determined. This value was used as a starting point and a minimal value required to transmit the image without loss was found.

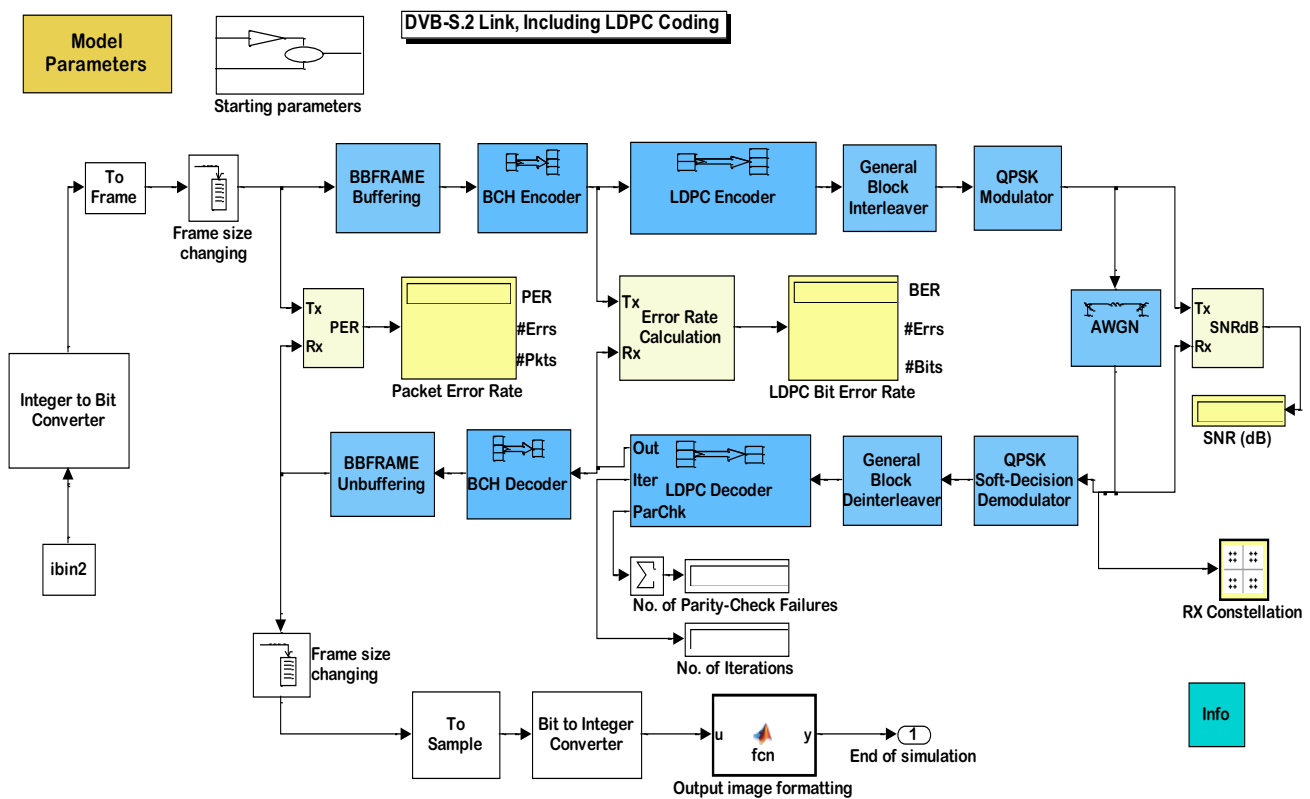

Figure 1. Simulation model of DVB-S2 system

III. SIMULATION RESULTS

For different parameters combinations, three conditions are tested, as can be seen in Table I:

- Transmission with an SNR value which prevents an image from being received (SNR_1), with corresponding BER and PER values (BER_1 and PER_1).
- Transmission with minimal number of errors where it is possible to reproduce a received image partially or completely (SNR_2) and its corresponding BER and PER values (BER_2 and PER_2).

- Transmission where the received image is error-free (SNR_3). In this case the corresponding BER and PER values (BER_3 and PER_3) equal 0 and are not shown.

Fig. 2 shows examples of two different images sent over the system/wireless channel. In case of QPSK modulation (Fig. 2a, c), SNR values of received image was equal to 0.832 dB and 1.439 dB. Received image is visually damaged and the constellation diagram shows high distortion in received signal. It means that it is necessary to increase the transmitting power in order to reduce BER and receive an image with higher quality. With 8PSK modulation (Fig. 2b, d), received image has much higher SNR values equal to 7.723 dB and 7.739 dB.

TABLE I. RESULTS OBTAINED FROM THE SIMULINK-DESIGNED MODEL

Modulation	Code ratio	PER ₁	BER ₁	SNR ₁	PER ₂	BER ₂	SNR ₂	SNR ₃
QPSK	1/4	0.0303	0.000126	-2.743	0	4.94E-05	-2.713	-2.658
QPSK	1/3	0.1031	0.000525	-1.456	0.05155	0.000175	-1.414	-1.314
QPSK	2/5	0.4296	0.006211	-0.616	0.1257	0.001238	-0.5863	-0.546
QPSK	1/2	0.1711	0.003086	0.777	0.02196	8.73E-05	0.8319	0.907
QPSK	3/5	1	0.08066	1.874	0.0929	0.000839	1.988	2.069
QPSK	2/3	0.0410	0.000866	2.86	0	1.65E-05	2.909	2.939
QPSK	3/4	0.1761	0.00711	3.846	0	1.72E-05	3.886	3.914
QPSK	4/5	0.9483	0.01453	4.413	0.0518	0.000329	4.544	4.576
QPSK	5/6	0.3526	0.000966	4.987	0	0	5.017	5.042
QPSK	8/9	0.2235	0.001542	5.987	0.06435	0.000162	6.072	6.087
QPSK	9/10	1	0.008957	6.087	0.066	0.000364	6.234	6.348
8PSK	3/5	1	0.62358	5.024	0	0	5.373	5.638
8PSK	2/3	0.4611	0.004302	6.295	0	0	6.423	6.558
8PSK	3/4	1	0.03948	7.473	0.126	0.001603	7.739	7.868
8PSK	5/6	0.2174	0.003973	9.097	0.08696	6.3E-05	9.187	9.238
8PSK	8/9	1	0.0195	10.04	1	0.015557	10.2	10.5
8PSK	9/10	1	0.0126	10.5	0	1.03E-05	10.755	10.83

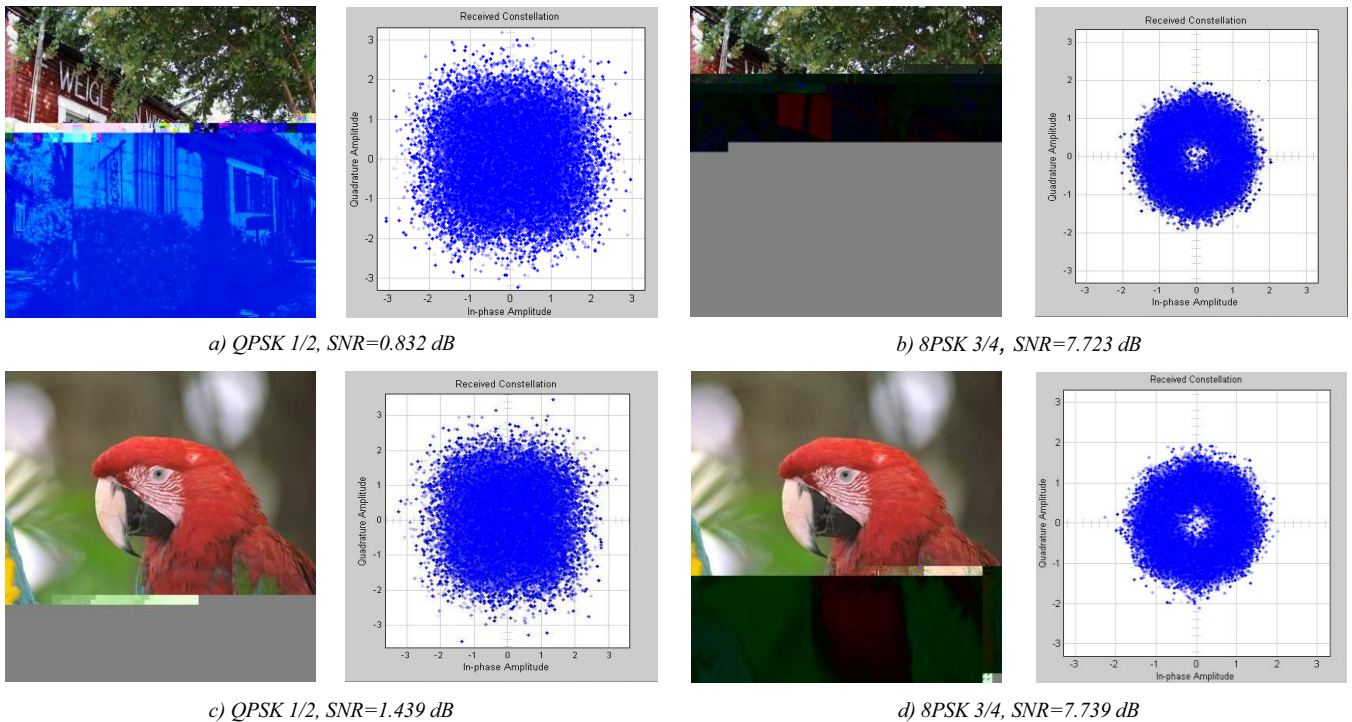

Figure 2. Simulation examples of received image and constellation diagram for two different modulations

According to simulated results it can be noted that QPSK modulation is more robust compared to 8PSK modulation due to being less sensitive to noise. In order to correctly transmit a symbol from the source to the destination, less energy per symbol is required for QPSK than for 8PSK for the same quality of the received symbol. At the same time, 8PSK modulation proves to be more efficient, with a spectral efficiency of 1.77-2.67 bit/s/Hz that is much higher than QPSK's spectral efficiency of 0.49-1.78 bit/s/Hz.

IV. MEASUREMENT RESULTS

Measurements were made using the digital signal parameter measuring instrument for several Astra 1 satellite (19,2° E) transponders. SNR ratio, BER before (BER_i) and after error correction (BER_o), and PER were measured for each transponder.

The results are shown in Table II. Lab-measured values showed that SNR values used in real systems are much higher than minimal values obtained in the Matlab simulation. Reasons for this is real wireless channel conditions with more types of noise than simulated, but also the restrictions in technical realization of real transmitters, receivers, and reproduction devices. Finally, a system margin including temperature and time dependency of the real devices should be taken into consideration. All these influences accumulate and increase the need for a SNR enlargements over the minimum value obtained through simulation for a given modulation scheme and transfer rate.

The measurement instrument is also capable of displaying a constellation diagram for the received signal, as shown in Fig. 3. Constellation diagrams for both modulations have corresponding shape meaning that there is no significant distortion in received signal. Also it can be noted that PER and BER (after BCH decoder) values are smaller than 10^{-9} . Reception of a signal with clear image was possible all the time during the measurements in accordance with measured BER and PER values.

TABLE II. MEASURED RESULTS OF A REAL-WORLD SYSTEM

Frequency (MHz)	Modulation/Code ratio	BER_i ($\cdot 10^{-2}$)	BER_o ($\cdot 10^{-9}$)	PER ($\cdot 10^{-6}$)	SNR (dB)
10806	8PSK 3/4	2.7	<5	<9	9.6
10835	8PSK 2/3	1.3	<5	<9	17.3
11129	8PSK 2/3	7	<5	<9	7.9
11174	8PSK 2/3	1	<5	<9	18.2
11306	8PSK 2/3	0.92	<5	<9	19.3
11365	8PSK 2/3	2.1	<5	<9	17.5
11467	8PSK 2/3	1.3	<5	<9	10.9
11497	8PSK 2/3	2.8	<5	<9	9.4
11585	8PSK 2/3	2.5	<5	<9	12.3
11644	8PSK 3/4	0.39	<5	<9	11.6
11994	QPSK 9/10	0.11	<5	<9	9.1

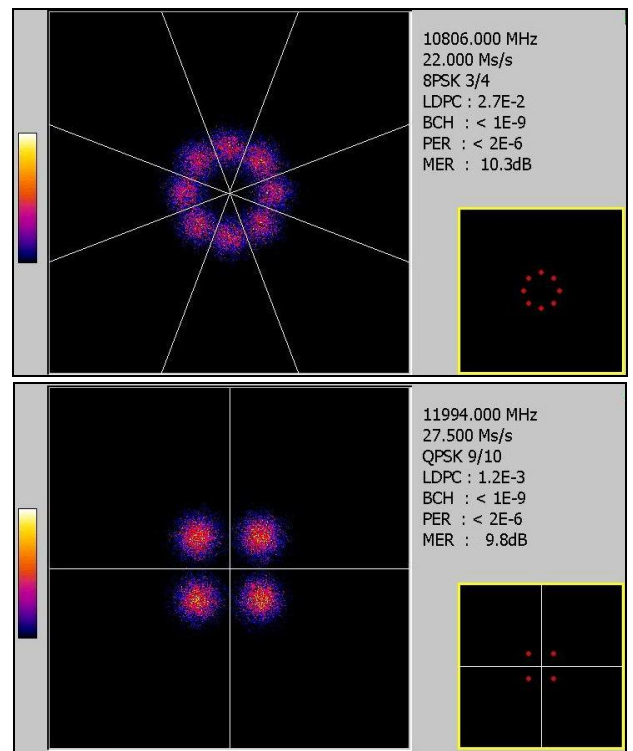

Figure 3. Constellation diagrams for QPSK and 8PSK modulations

V. CHOOSING THE OPTIMAL PARAMETERS

Choosing the optimal operation parameters for a DVB-S2 system depends mostly on two factors: channel conditions and the required bit rate. Channel conditions usually dictate the type of the modulation scheme to be used, while the bit rate is set according to the complexity and quantity of content that needs to be transmitted. The results in Table III show the maximum useful bit rate for a specific modulation scheme and code ratio, and the minimum SNR value required to transmit error-free content, obtained using the Matlab-designed simulation. Useful bit rate is calculated under the presumption of symbol rate of 27500 Mbaud/s and channel bandwidth of 36 MHz [3].

From Table III we can observe two boundary cases, depending on the radio channel conditions:

- During unfavorable transmission channel conditions QPSK modulation with 1/2 code ratio should be used, providing a good ratio of the SNR value and achieved useful bit rate, whilst being very robust in case of errors.
- In normal transmission channel conditions, usage of the 8PSK modulation scheme with 3/4 code ratio is suggested, providing a useful bit rate of 61 Mbit/s.

Using the adaptive encoding in the DVB-S2 system, modulation scheme and code ratio can be adjusted between these two boundary cases, depending on requirements and channel conditions.

TABLE III. USEFUL BIT RATE AND MINIMAL SNR FOR A GIVEN MODULATION SCHEME AND CODE RATIO

Modulation	Code ratio	Useful bitrate (kbit/s)	Minimum SNR (our result)
QPSK	1/4	13481.68	-2.658
QPSK	1/3	18052.32	-1.314
QPSK	2/5	21708.83	-0.546
QPSK	1/2	27193.59	0.907
QPSK	3/5	32678.36	2.069
QPSK	2/3	36361.95	2.939
QPSK	3/4	40905.50	3.914
QPSK	4/5	43647.89	4.576
QPSK	5/6	45503.23	5.042
8PSK	3/5	48949.75	5.638
QPSK	8/9	48577.40	6.087
QPSK	9/10	49186.83	6.348
8PSK	2/3	54467.49	6.558
8PSK	3/4	61273.41	7.868
8PSK	5/6	68160.45	9.238
8PSK	8/9	72765.33	10.5
8PSK	9/10	73678.19	10.83

VI. CONCLUSION

In this paper the basic technical features and principles of the DVB-S2 system are described. Simulation of DVB-S2 transmission through AWGN channel was done by using two modulations: QPSK and 8PSK with different code ratios. Results of simulation showed that QPSK modulation is more robust to noise than 8PSK modulation in same transmission conditions. 8PSK modulation gives higher spectral efficiency but requires enlargement of required SNR value for error-free reception.

Obtained simulation results were compared with the measurement results in real DVB-S2 system. Measured values

showed that SNR values used in real DVB-S2 system are much higher than minimal values obtained in the simulation because of real wireless channel conditions that include different sources and types of noise.

Results are analyzed and used to propose an optimal type of modulation scheme and error correction ratio depending on bit rate requirements and channel conditions.

Future research may include modifying the simulation for video signal transmission, signal parameter measurements in the Ricean channel, and introducing the transmission channel estimator and its influence on the entire signal transmission. As a final result, a proposal of optimal combination of all DVB-S2 parameters in regard to a specific purpose and usage conditions should be made.

ACKNOWLEDGMENT

The work described in this paper was conducted under the research projects: "Picture Quality Management in Digital Video Broadcasting" (036-0361630-1635) supported by the Ministry of Science, Education and Sports of the Republic of Croatia.

REFERENCES

- [1] ETSI EN 302 307 (V1.3.1), Digital Video Broadcasting (DVB); Second generation framing structure, channel coding and modulation systems for Broadcasting, Interactive Services, News Gathering and other broadband satellite applications (DVB-S2), March 2013
- [2] EN 301 790 (V1.5.1), Digital Video Broadcasting (DVB); Interaction channel for satellite distribution systems, May 2009
- [3] ETSI TR 102 376 (V1.1.1), Digital Video Broadcasting (DVB); User guidelines for the second generation system for Broadcasting, Interactive Services, News Gathering and other broadband satellite applications (DVB-S2), February 2005
- [4] A. Morello and V. Mignone: DVB-S2: The Second Generation Standard for Satellite Broad-band Services, Proceedings of the IEEE, vol. 94, iss. 1, pp. 210 - 227, January 2006